

Einbau / Installation

**CARGRAPHIC
Mass Flow Sensor Kit
BOSCH GEN2**

**for
Porsche 964
3.6L**



Disclaimer:

The contents listed in these operating instructions / installation instructions were created with great care.

CARGRAPHIC Thomas Schnarr GmbH assumes no responsibility for the completeness, timeliness and accuracy of the listed content.

The user bears the risk of using the content.

CARGRAPHIC Thomas Schnarr GmbH assumes no responsibility for damage caused by operation, improper handling and maintenance or in any related way.

Notes:

The installation should be done by a specialist workshop!

! Important:

Please read carefully the technical bulletin on page 7.

To run the CARGRAPHIC MAF Sensor Kit, all coding bridges/ connections must be disconnected!

1. Remove the engine control unit under the driver's seat and open the cover by carefully bending up the clips.

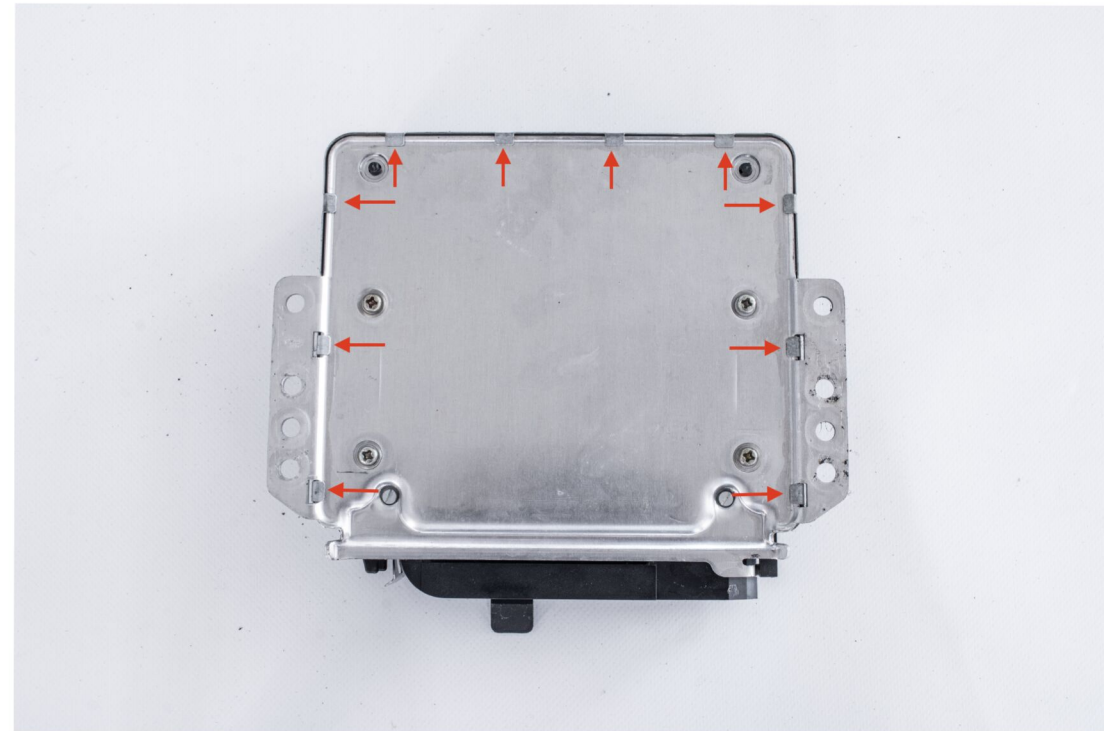

2. Carefully loosen the upper circuit board from the fastening (1) and lever out the locking lugs (2) on the left and right to secure the circuit board (3). push it backwards and unfold it.

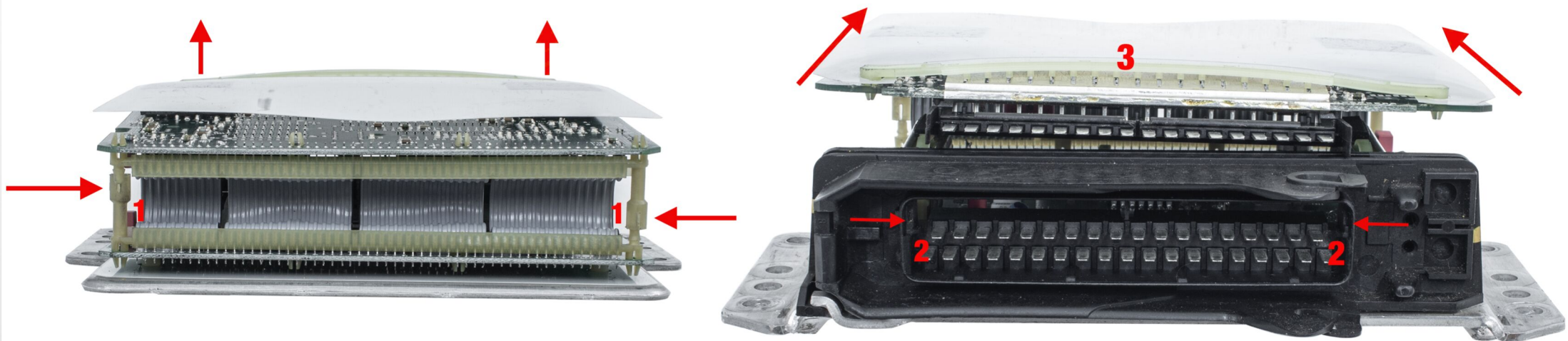

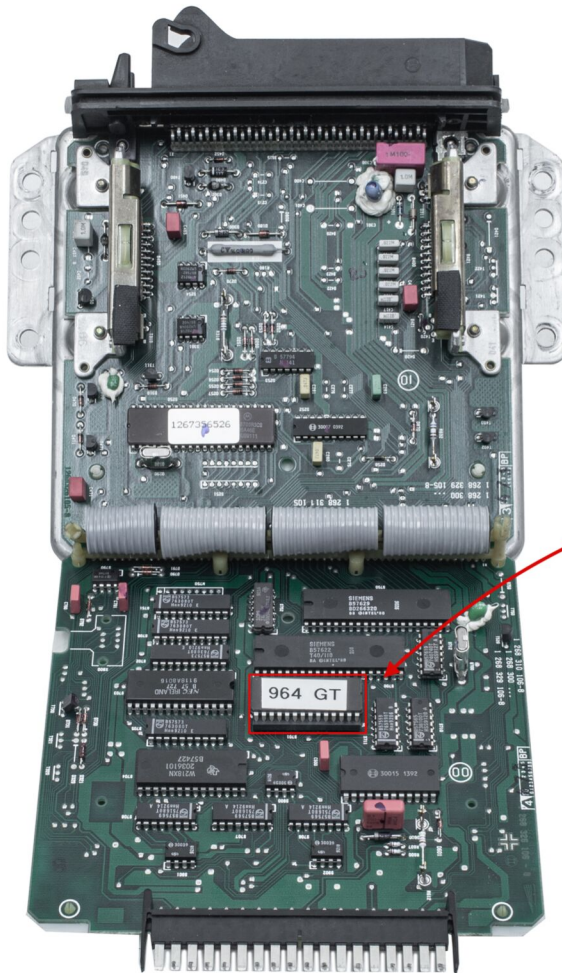

3. Gently pull out the original chip up and swap this for that CARGRAPHIC chip.



Caution:
Make sure that the notch is on in the same place as the old chip.

4. Reassemble the control unit in reverse order.



Technical bulletin

In order to cover the various legal country regulations and vehicle variants, the corresponding corresponding maps are integrated in the DME control unit. These can be read directly with the system tester 9288 under the menu item "Actual values".

Do not carry out any system configuration with the system tester!

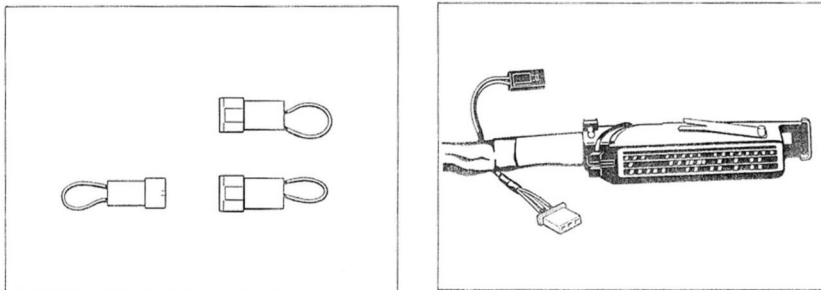

To call up these characteristic diagrams, a 2-pole and a 3-pole stretch connection are made within the DME cable harness. These are bridged/ connected differently depending on the country version.

To run the CARGRAPHIC MAF Sensor Kit, all coding connections must be disconnected!

OE



MAF



09/2023

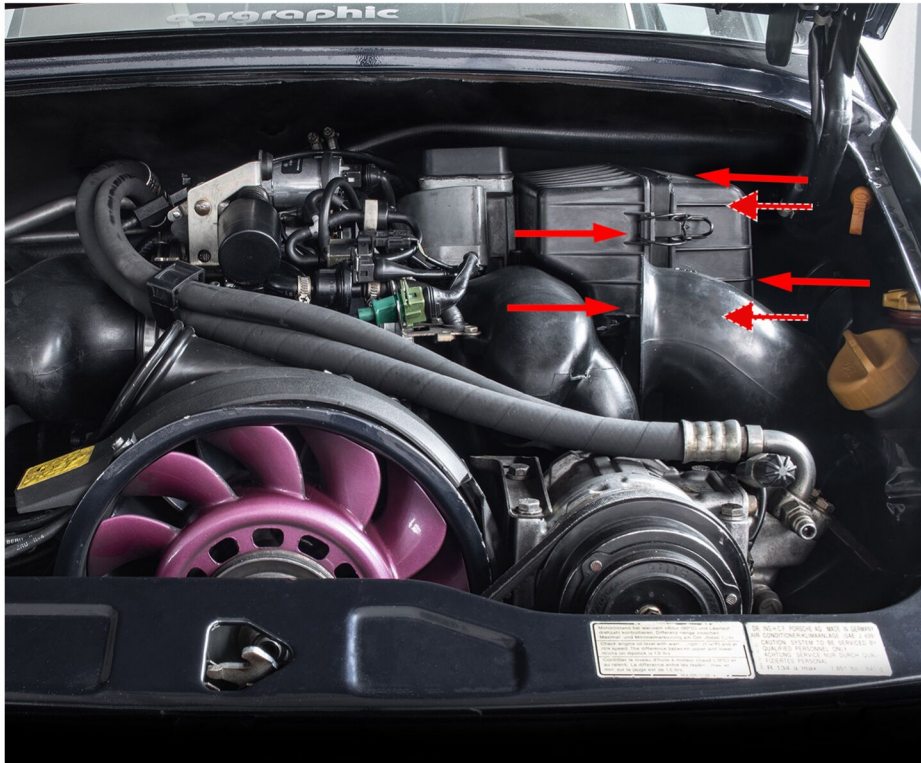

5. Remove air filter and air flow meter

- open the 4 clamps of the air filter box and remove the box - the 4 fastenings remove from air box
- Remove the vacuum line from the vacuum accumulator and the box Remove
- Loosen the hose clamp on the air flow meter and remove the plug

6. Installation wiring harness

Connect the red cable to the plug of the MAF sensor thread through the cable duct and attach it to the existing red cable in the wiring harness. Close the connection carefully.

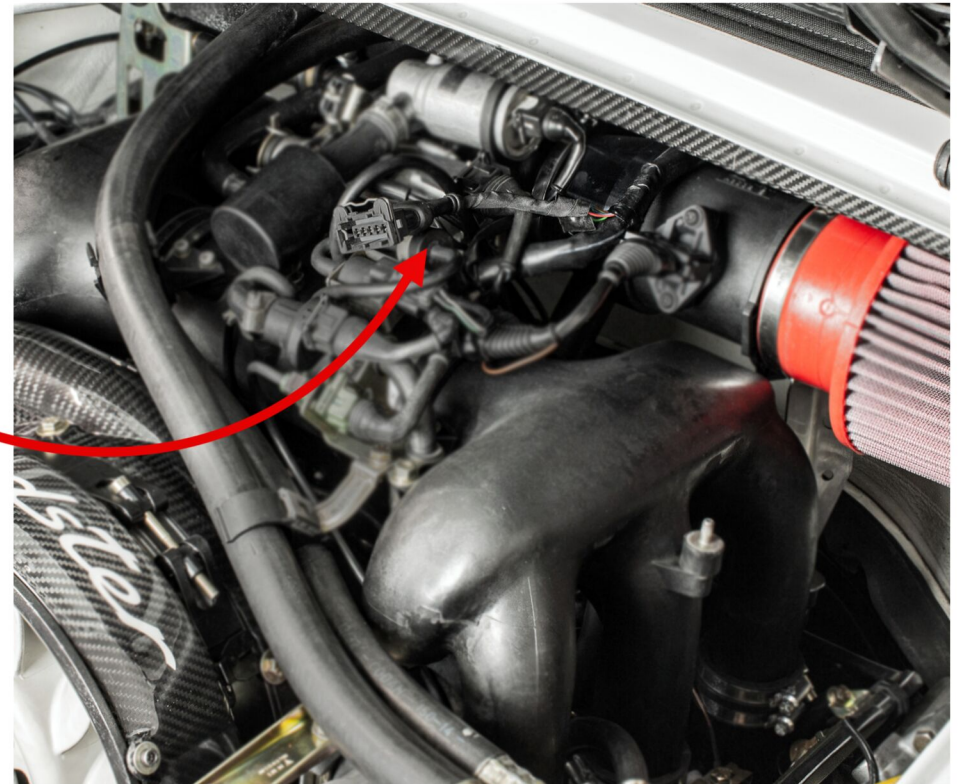
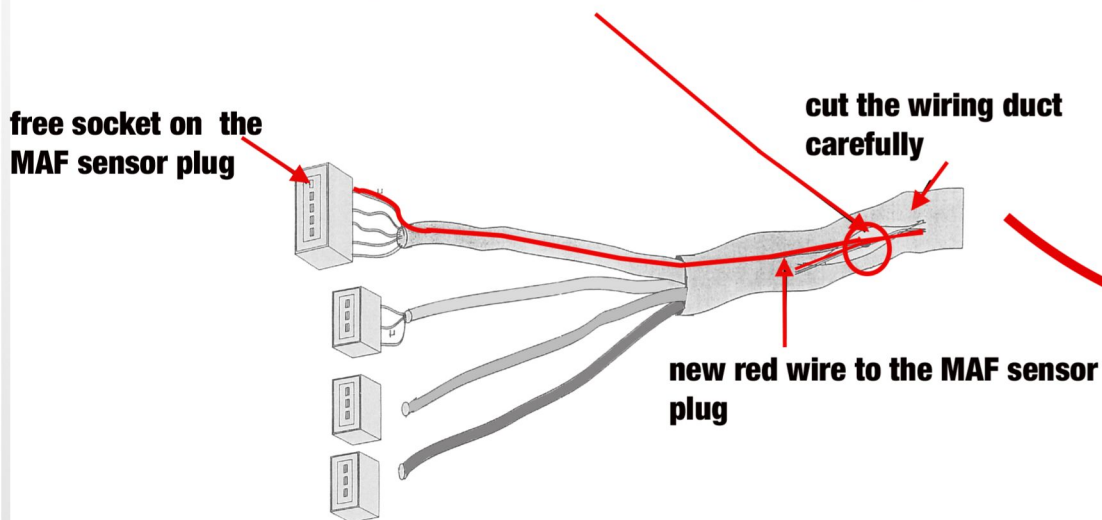

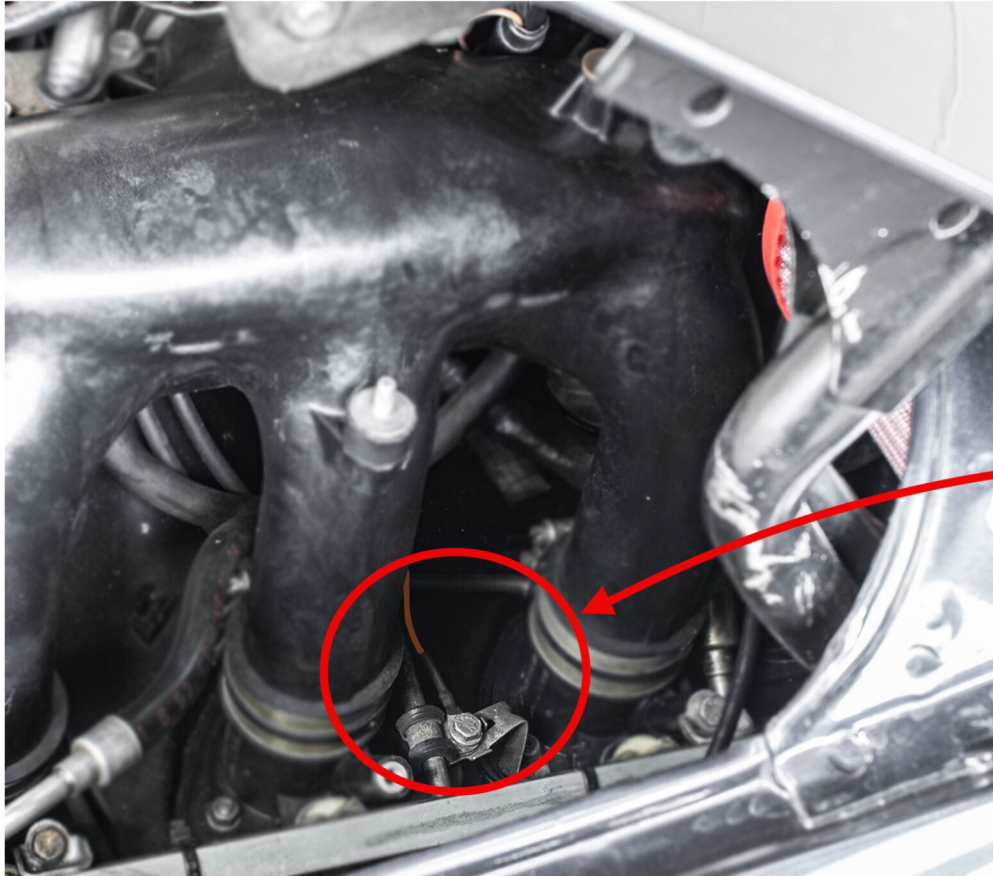

7. installing air filter kit:

- Set the MAF sensor with the air filter in the inlet hose and bring it in the right position
- screw the bracket of the filter on the manifold
- plug in the connection of the MAF sensor
- reconnect the ventilation hose
- tighten the clamp

Attach the ground connection with the enclosed screw under the rubber buffer on the intake manifold.

